

SHARON TWP
9 MI 1 (11)

SONS OF UNION VETERANS OF THE CIVIL WAR

DEPARTMENT OF MICHIGAN

CIVIL WAR MEMORIAL RECORD

PLEASE:

- Type or print, using a ball-point pen when filling out this form. Legibility is critical.
- Do not guess at the information. An answer of, "Unknown," is more helpful.
- Include a photograph of each viewable side and label it with name & direction of view.

- Thank You.

Type of Memorial

Monument *with* Sculpture
 Monument without Sculpture

Monument with *Cannon*
 Historical Marker Plaque

Affiliation

G.A.R. (Post No. _____)
 W.R.C. (Corps No. _____)
 S.U.V.C.W. (Camp No. _____)
 D.U.V.C.W. (Tent No. _____)

M.O.L.L.U.S.
 Other Allied Order
Which? _____
 Other: UNKNOWN

Dedication Date _____

Unknown

Location

The Memorial is *currently* located at: NORTHEAST CORNER WHERE SYLVAN RD. DEADENDS AT PLEASANT LAKE RD
Street/Road address or site location _____
City/Village _____ Township SHARON County WASHTENAW

The front of the Memorial faces: North South East West

Government Body, Agency, or Individual Owner (of private cemetery that Memorial is located in)...

Name SHARON TWP Dept./Div. _____
Street Address 18010 PLEASANT LAKE RD.
City MANCHESTER State (if not Michigan) MI Zip Code 48158
Contact Person _____ Telephone (313) 428-7591

If Memorial has been moved, please list former location(s)...

Physical Details

Material of Monument or base under a Sculpture or Cannon = Stone Concrete Metal Undetermined
If known, name specific material (color of granite, marble, etc.) _____

Material of the Sculpture = Stone ___ Concrete ___ Metal ___ Undetermined
If known, name specific material (color of granite, marble, etc.) _____
If the Sculpture is of metal, is it solid cast or "hollow?" _____

Material of Plaque or Historical Marker / Tablet = NONE

Material of Cannon = ___ Bronze ___ Iron - Consult known Ordnance Listing to confirm
Markings on muzzle = _____

Markings on Left Trunion _____ Right Trunion _____

Is inert ammunition a part of the Memorial? ___ If so, describe _____

Approximate Dimensions (indicate unit of measure) - taken from tallest / widest points
Monument or Base: Height 25' Width 5'-8" Depth 5'-8" or Diameter _____
Sculpture: Height 2' Width 2' Depth 1' or Diameter _____

For Memorials with multiple Sculptures, please record this information on a separate sheet of paper for each statue and attach to this form. Please describe the "pose" of each statue and any weapons/implements involved (in case your photos become separated from this form). Thank you!

Markings/Inscriptions (on stone-work / metal-work of monument, base, sculpture)

Maker or Fabricator mark / name? If so, give name & location found _____

The "Dedication Text" is formed: cut into material ___ raised up from material face
MENS NAMES DATES ETC " " "

Record the text (indicate any separation if on different sides...) Please use additional sheet if necessary.
SEE ATTACHMENTS FOR TEXT ON ALL 4 SIDES

Environmental Setting

(The general vicinity and immediate locale surrounding a memorial can play a major role in its overall condition.)

Type of Location

- | | | |
|---|---|--|
| <input type="checkbox"/> Cemetery | <input type="checkbox"/> Park | <input type="checkbox"/> Plaza/Courtyard |
| <input type="checkbox"/> "Town Square" | <input type="checkbox"/> Post Office | <input type="checkbox"/> School |
| <input type="checkbox"/> Municipal Building | <input type="checkbox"/> State Capitol | Other: <u>ON SITE OF</u> |
| <input type="checkbox"/> Courthouse | <input type="checkbox"/> College Campus | <u>OLD SHARON</u> |
| <input type="checkbox"/> Traffic Circle | <input type="checkbox"/> Library | <u>TOWN HALL</u> |

Does water collect in recessed areas of the Memorial? Yes No Unable to tell

Surface Coating

Does there appear to be a coating? Yes No Unable to determine
If known, identify type of coating.

Gilded Painted Varnished Waxed Unable to determine

Is the coating in good condition? Yes No Unable to determine

Basic Surface Condition Assessment (check one)

In your opinion, what is the general appearance or condition of the Memorial?

Well maintained Would benefit from treatment In urgent need of treatment Unable to determine

Overall Description

Briefly describe the Memorial (affiliation / overall condition & any concern not already touched on) .

Supplemental Background Information

In addition to your on-site survey, any additional information you can provide on the described Memorial will be welcomed. Please label each account with its source (author, title, publisher, date, pages). Topics include any reference to the points listed on this questionnaire, plus any previous conservation treatments - or efforts to raise money for treatment. Thank you.

Inspector Identification

Date of On-site Survey 5-6-98

Your Name GARY WOODMAN

Address 1511 KENSINGTON City JACKSON

State (If Non-Michigan Resident) MI Zip Code 49203 Telephone 

Please send completed **Civil War Memorial Record** to:

Kim Leese
1902 Green St.
Saginaw, MI 48602

Thank you for your help, and attention to detail.

Kent Armstrong, Chair
Memorials Subcommittee - Department of Michigan

General Vicinity

- Rural (low population, open land) Suburban (residential, near city)
 Town Urban / Metropolitan

Immediate Locale (check as many as may apply)

- Industrial Commercial
 Street/Roadside within 20 feet Tree Covered (overhanging branches)
 Protected from the elements (canopy or enclosure, indoors)
 Protected from the public (fence or other barrier)
 Any other significant environmental factor _____

Condition Information

Structural Condition (check as many as may apply)

The following section applies to Monuments *with* Sculpture, and Monuments *without* Sculpture - including the base for Monuments with *Cannon*. Instability in the sculpture and its base can be detected by a number of factors. Indicators may be obvious or subtle. Visually examine the sculpture and its base.

	Sculpture	Base
If hollow, is the internal support unstable/exposed? (look for signs of exterior rest)	=	=
Any evidence of structural instability? (look for cracked joints, missing mortar or caulking or plant growth)	YES	YES
Any broken or missing parts? (look for elements (i.e., sword, musket, hands, arms, etc. - missing due to vandalism, fluctuating weather conditions, etc.)	NO	NO
Any cracks, splits, breaks or holes? (also look for signs of uneven stress & weakness in the material)	NO	YES

Surface Appearance (check as many as may apply)

	Sculpture	Base
Black crusting	—	—
White crusting	—	—
Etched, pitted, or otherwise corroded (on metal)	—	—
Metallic staining (run-off from copper, iron, etc.)	—	—
Organic growth (moss, algae, lichen or vines)	—	—
Chalky or powdery stone	—	—
Granular eroding of stone	—	YES
Spalling of stone (surface splitting off)	—	YES
Droppings (bird, animal, insect remains)	—	—
Other (e.g., spray paint graffiti) — Please describe...		
<u>LOWER BASE HAS MOVED LEAVING VOIDS</u> <u>NUMEROUS CRACKS IN STONE</u>		

(11)

1 of 4

SOUTH SIDE

EAGLE PERCHED ON CROSSED
CANNON ABOVE SHIELD WITH
CROSSED FLAGS ON EITHER SIDE

SACRED
TO THE MEMORY OF
ABRAHAM LINCOLN
PRESIDENT
OF THE UNITED STATES
DIED
BY THE HAND OF AN ASSASSIN
APRIL 15 AD 1865
A MARTYR TO FREEDOM

(11)

2 of 4

EAST SIDE

CROSSED FLAGS

HORACE ROWE⁽³⁾ CO. B 20 INF
DIED OF WOUNDS AT WASHINGTON DC JULY 14 1864⁽¹⁾

FRED. C. NUEBLING CO. B 20 INF
DIED AT BALTIMORE MD APRIL 14 1863

JOHN NUEBLING JR CO. B 20 INF
KILLED IN ACTION PETERSBURG VA JULY 30 1864

WILSON A. LEWIS CO. B 20 INF
DIED AT KNOXVILLE TENN⁽²⁾ DEC 20 1863

WATSON CARPENTER CO. F 20 INF
KILLED IN ACTION PETERSBURG JULY 30 1864

CARLOS C. DORR CO. F 20 INF
DIED AT COVINGTON KY AUGUST 12 1863

JAMES L. IRWIN CO. F 20 INF
DIED FROM WOUND A PETERSBURG VA JUNE 18 1864

CHARLES E. TOWNSEND CO. F 20 INF
KILLED IN ACTION SPOTTSYLVANIA MAY 12 1864

FROM MICHIGAN REGIMENTAL HISTORIES

- (1) JUNE 15 1864
- (2) NOV 30 1863
- (3) ROWE
=

(11)

WEST SIDE

4 of 4

CROSSED FLAGS

JAMES CUFF CO, F 20 INF
DIED AT ANDERSONVILLE GA, AUG 20 1864
RANSOM P, ① JONES CO, F 20 INF
DIED OF WOUNDS WASHINGTON DC JUNE 29 1864
JOHN LEBARON CO, K 20 INF
DIED AT REVANNA OHIO OCTOBER 17 1864
FRANCIS S. LEBARON CO, K 20 INF
DIED AT SHARON MICH DEC 25 1866
BENJ. FAIRCHILD ③ HOSP, STEWARD 26 INF
DIED NEAR NEW YORK CITY AUG, ④ 18 1863
SAMUEL A. HEWES CO, H 2 INF
DIED AT WASHINGTON DC MAY 8 ⑤ 1864
JOHN LEHMAN ⑥ CO, C 7 INF
DIED OF WOUNDS AT WILDERNESS MAY 6 1864
CHARLES BOUCHER CO, K 1 INF
KILLED IN ACTION 2 BULL RUN VA AUG 30 1862

FROM REGIMENTAL HISTORIES

- ① RANSOM J JONES
- ② NOV 26 1864
- ③ FAIRCHILDS
- ④ JULY 18 1863
- ⑤ MAY 7 1865
- ⑥ LEAMON

(11)

NORTH SIDE

3 of 4

STATE SEAL

WM J. McCORD CO. I 14 INF
DIED OF WOUNDS ATLANTA GA JULY 28 1864
MARTIN DUBOIS(E)^① CO. K^② 1 INF
DIED NEAR HARRISONS LANDING AUG. 10 1862
AZARIAS DUBOIS CO. A^③ 9 CAVALRY^④
DIED AT SHARON MICH. JULY 28 1864
GEORGE MANCHESTER CO. L 2 CAVALRY
DIED AT NASHVILLE TENN JUNE 23^⑤ 1864
FOSTER AMES CO. E 17 INF
DIED AT LEBANON KY APRIL 30^⑥ 1863
DANIEL GRAY CO. D 28 INF
DIED AT CHARLOTTE N.C JUNE 3^⑦ 1865
JAMES ARMSTRONG CO. D 28 INF
DIED AT CAMP NELSON KY NOV 25^⑧ 1864
CHARLES BABCOCK CO. G 11 INF
DIED AT CHATTANOOGA TENN APRIL 15 1865

FROM MICHIGAN REGIMENTAL HISTORIES

- ① DUBOISE
- ② CO. C
- ③ CO. D
- ④ 1ST INF
- ⑤ DEC 23 1864
- ⑥ APRIL 29 1863
- ⑦ JUNE 10 1865
- ⑧ NOV 27 1864

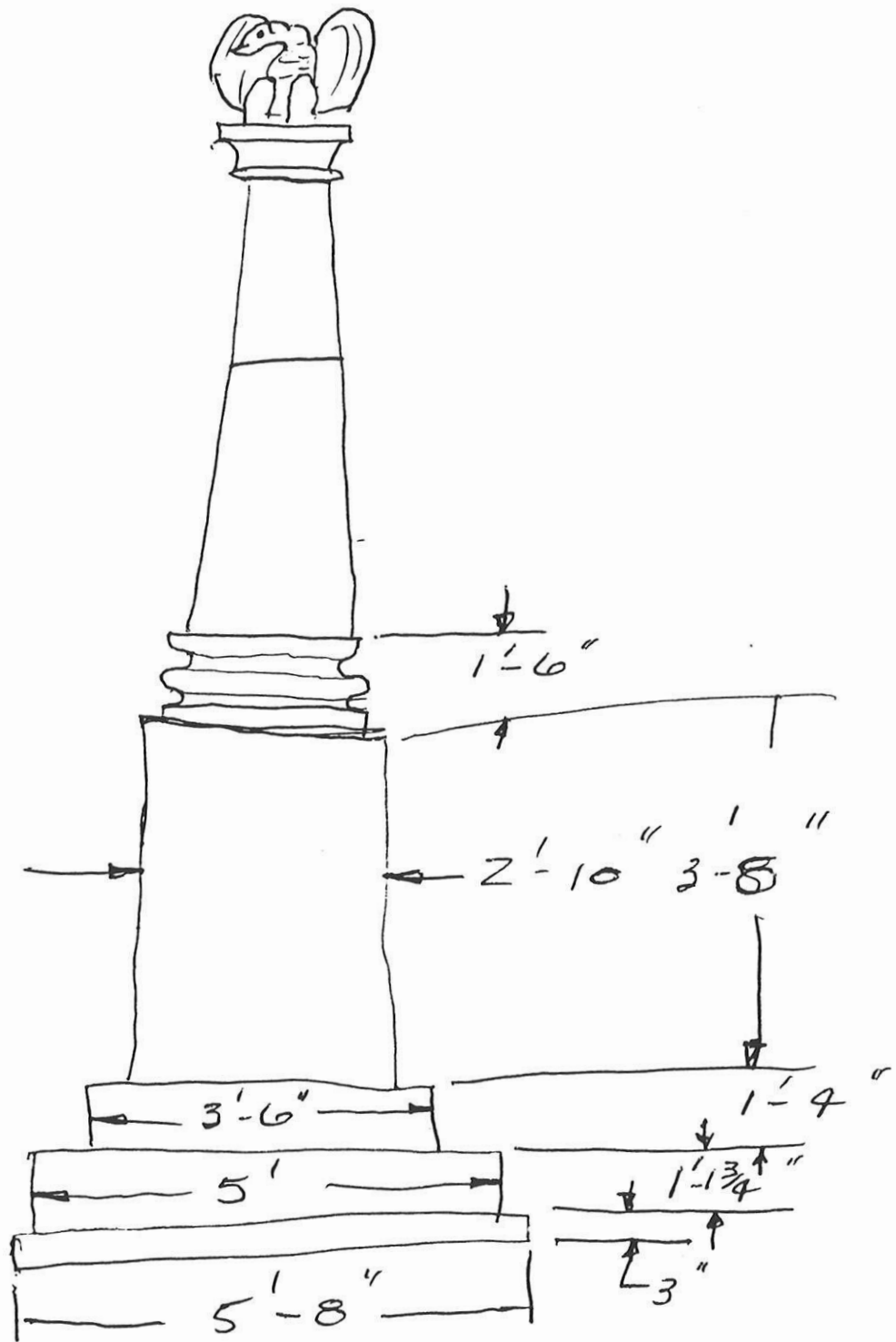



—Citizen Patriot Photograph.

HEROES NEVER FORGOTTEN—Although most descendants of Sharon's Civil war heroes have drifted far away, the 24 fallen heroes whose names are listed on this monument, located on Sharon Hollow Rd., between Grass Lake and Manchester, are never forgotten. Direct descendants of two veterans from that war, one killed in action, are the four children of Mr. and Mrs. Donald Irwin. Many pilgrimages are made by this foursome to the monument to keep it covered with wild flowers. From left are Nancy, Dick, Beth and Barbara.

Sharon Descendants of Civil War Hero Maintain Monument

BY BOB McGRAGOR

(Citizen Patriot Staff Reporter.)

Sharon—Nestling on the rim of scenic Sharo valley, between Grass Lake and Manchester, the imposing monument to Sharon's Civil war heroes and Abraham Lincoln, holds court.

The only challenge to this tribute to the 24 fallen warriors whose names are inscribed on the monument, was the 1917 cyclone which ripped through that area, breaking off part of the shaft and completely razing the Sharon Center Methodist church and the township hall across the street.

MONUMENT REPAIRED.

Although the monument was repaired, the church and hall were not rebuilt on the same sites.

The present township hall is adjacent to the monument on the east.

Typical of the families which are descendants of the fallen heroes of the Civil war is that of Donald Irwin.

The Irwin children, Beth, 11, Nancy, 10, Dick, 8, and Barbara 6, have more than history at stake when they make their frequent pilgrimages to the monument to place wild flowers on its base.

Their great-grandfather, John Irwin, was a veteran, and his brother, James, whose name is on the monument, died in action.

GREAT UNCLE.

Mrs. Dorr Putnam, of East Grass Lake had a great uncle, John Lehman, whose name also appears with those of the fallen heroes.

Although descendants of those whose names are listed have long since drifted away, they can rest assured that with the younger Irwins coming up and making their homes in the Sharon valley area, the dead from that war won't be overlooked.

Sharon Twp, Michigan



Memorial Boulder with Plaque next to Civil War Monument



This marker serves as an everlasting tribute to the memory of our martyred president Abraham Lincoln (assassinated April fifteenth 1865) and also the 24 Sharon township men who died in the war for the protection of our union, this marble monument was erected in the eighteen seventy at a cost of \$1,500 and was paid by subscription. The designer and builder was Eisele of Ann Arbor, Michigan.